

# Werkzeugkatalog

tool catalogue



# SPINNER

BMT 45

TC 300 MC

TC 300 MCY

TC 300 SMCY



Hinweis zu den AGBs:

Diese finden Sie in unserem Internetauftritt unter

[www.heimatec.de](http://www.heimatec.de)

Home/Impressum/AGB

Terms and conditions:

You will find them on our website

[www.heimatec.com](http://www.heimatec.com)

Home/Imprint/Terms and Conditions

Das Katalog-Werk einschließlich aller seiner Teile ist urheberrechtlich geschützt. Jede Verwertung außerhalb der engen Grenzen des Urheberrechtsgesetzes ist ohne Zustimmung der Rechteeinhaber unzulässig und strafbar. Das gilt insbesondere für Vervielfältigungen, Übersetzungen, Mikroverfilmungen und die Einspeicherung und Verarbeitung in elektronischen Systemen.

**heimatec® GmbH** behält sich Änderungen technischer Art jederzeit ohne Vorankündigung vor. Dies gilt insbesondere bei Anpassungen an neue oder geänderte internationale Normen oder bei Weiterentwicklungen unserer Produkte oder Herstellungsprozesse.

This catalogue, including all its parts, is protected by copyright. Each use outside the restricted limitations of the Copyright Act is inadmissible and liable to prosecution without the consent of heimatec. This is particularly valid for duplication, translation, microfilming and feeding and processing in electronic systems.

**heimatec® GmbH** reserves the right of technical changes everytime without advance notice, which is particularly valid for adaptions to new or changed international standards, or to developments of our products or manufacturing processes.

## angetriebene Werkzeuge

driven tools



**Axial-Bohr- und Fräskopf**  
axial drilling and milling head

$n_{max} = 6000 \text{ min}^{-1}$

8 010 45 126	ER 25 AX u-tec	EK	1:1
8 010 45 127	ER 25 AX u-tec	IK 25 bar	1:1
8 010 45 128	ER 25 AX u-tec	IK 70 bar	1:1
8 010 46 230	easy-quick HT 4	EK	1:1
8 010 46 231	easy-quick HT 4	IK 25 bar	1:1
8 010 46 232	easy-quick HT 4	IK 70 bar	1:1



**Axial-Bohr- und Fräskopf**  
axial drilling and milling head

$n_{max} = 24000 \text{ min}^{-1}$

8 013 44 014	ER 16 AX u-tec	EK	1:4
8 013 44 015	ER 16 AX u-tec	IK 70 bar	1:4



**Axial-Fräskopf**  
axial milling head

$n_{max} = 6000 \text{ min}^{-1}$

8 011 44 026	Kombidorn/universal arbor 16	EK	1:1
8 011 45 034	Kombidorn/universal arbor 22	EK	1:1
8 011 44 027	Kombidorn/universal arbor 1/2"	EK	1:1
8 011 44 028	Kombidorn/universal arbor 3/4"	EK	1:1

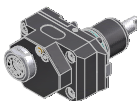

**Axial-Bohr- und Fräskopf**  
axial drilling and milling head

Achsversatz / offset  $A=42$

8 019 45 147	ER 25 AX u-tec	EK	1:2
8 019 45 148	ER 25 AX u-tec	IK 140 bar	1:2
$n_{max} = 12000 \text{ min}^{-1}$			
8 019 45 149	ER 25 AX u-tec	EK	1:3
8 019 45 150	ER 25 AX u-tec	IK 140 bar	1:3
$n_{max} = 18000 \text{ min}^{-1}$			
8 019 45 151	ER 25 AX u-tec	EK	2:1
8 019 45 152	ER 25 AX u-tec	IK 140 bar	2:1
$n_{max} = 3000 \text{ min}^{-1}$			

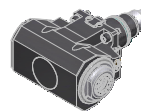
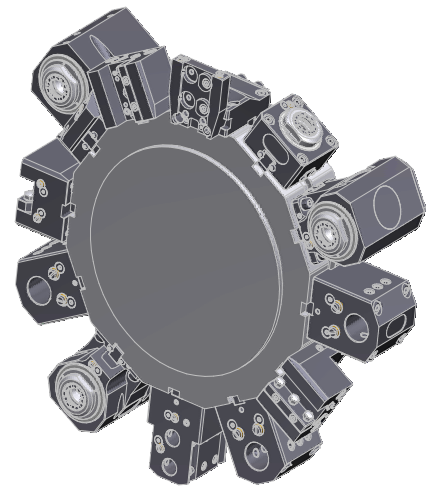

**Winkel-Bohr- und Fräskopf**  
radial drilling and milling head

Mittenmaß / center distance  $H=85$   
 $n_{max} = 6000 \text{ min}^{-1}$

8 030 45 262	ER 25 AX u-tec	EK	1:1
8 030 45 263	ER 25 AX u-tec	IK 140 bar	1:1
8 030 46 413	easy-quick HT 4	EK	1:1
8 030 46 414	easy-quick HT 4	IK 140 bar	1:1

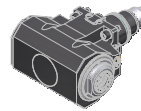

**Winkel-Bohr- und Fräskopf**  
radial drilling and milling head

Mittenmaß / center distance  $H=85$   
 $n_{max} = 3000 \text{ min}^{-1}$

8 030 45 264	ER 25 AX u-tec	EK	2:1
8 030 45 265	ER 25 AX u-tec	IK 140 bar	2:1
8 030 46 415	easy-quick HT 4	EK	2:1
8 030 46 416	easy-quick HT 4	IK 140 bar	2:1

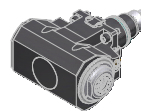

**Winkel-Bohr- und Fräskopf**  
radial drilling and milling head

Mittenmaß / center distance  $H=85$   
 $n_{max} = 12000 \text{ min}^{-1}$

8 030 45 266	ER 25 AX u-tec	EK	1:2
8 030 45 267	ER 25 AX u-tec	IK 140 bar	1:2
8 030 46 417	easy-quick HT 4	EK	1:2
8 030 46 418	easy-quick HT 4	IK 140 bar	1:2

► Weitere Ausführungen auf Anfrage  
further versions on request

► Zubehör **ZB...\***  
accessories **ZB...\***

► **easy-quick**

► **u-tec**

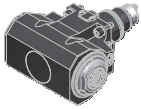

### Winkel-Bohr- und Fräskopf radial drilling and milling head

Mittenmaß / center distance H=85  
n<sub>max</sub> = 18000 min<sup>-1</sup>

8 030 45 268	ER 25 AX u-tec	EK	1:3
8 030 45 269	ER 25 AX u-tec	IK 140 bar	1:3
8 030 46 419	easy-quick HT 4	EK	1:3
8 030 46 420	easy-quick HT 4	IK 140 bar	1:3



### Winkel-Bohr- und Fräskopf radial drilling and milling head

Mittenmaß / center distance H=85  
n<sub>max</sub> = 24000 min<sup>-1</sup>

8 030 44 092	ER 16 AX u-tec	EK	1:4
8 030 44 093	ER 16 AX u-tec	IK 140 bar	1:4



### Winkel-Fräskopf radial milling head

Mittenmaß / center distance H=85  
n<sub>max</sub> = 6000 min<sup>-1</sup>

8 031 44 040	Kombidorn/universal arbor 16	EK	1:1
8 031 45 049	Kombidorn/universal arbor 22	EK	1:1
8 031 44 041	Kombidorn/universal arbor 1/2"	EK	1:1
8 031 44 042	Kombidorn/universal arbor 3/4"	EK	1:1

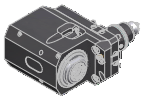

### Winkel-Bohr- und Fräskopf radial drilling and milling head

Mittenmaß / center distance H=85  
zurückgesetzt / offset  
n<sub>max</sub> = 6000 min<sup>-1</sup>

8 033 45 048	ER 25 AX u-tec	EK	1:1
8 033 45 049	ER 25 AX u-tec	IK 140 bar	1:1
8 033 46 149	easy-quick HT 4	EK	1:1
8 033 46 150	easy-quick HT 4	IK 140 bar	1:1



### Winkel-Bohr- und Fräskopf radial drilling and milling head

Mittenmaß / center distance H=85  
doppelspindlig / double spindle  
n<sub>max</sub> = 6000 min<sup>-1</sup>

8 039 45 089	ER 25 AX u-tec	EK	1:1
8 039 46 063	easy-quick HT 4	EK	1:1

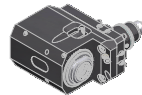
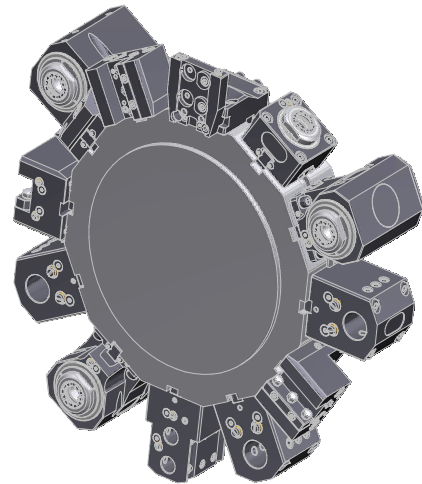

### Winkel-Bohr- und Fräskopf radial drilling and milling head

Mittenmaß / center distance H=85  
doppelspindlig / double spindle  
zurückgesetzt / offset  
n<sub>max</sub> = 6000 min<sup>-1</sup>

8 039 45 090	ER 25 AX u-tec	EK	1:1
8 039 46 064	easy-quick HT 4	EK	1:1



### Schwenkkopf universal head

8 043 44 032	ER 16 AX u-tec	EK	1:1
8 043 44 033	ER 16 AX u-tec	IK 25 bar	1:1
n <sub>max</sub> = 6000 min <sup>-1</sup>			
8 043 44 034	ER 16 AX u-tec	EK	1:2
8 043 44 035	ER 16 AX u-tec	IK 25 bar	1:2
n <sub>max</sub> = 12000 min <sup>-1</sup>			



### Winkel-Scheibenfräserkopf radial disk mill head

auf 0° absteckbar / 0° can be pinned  
kein Kühlmittel / no coolant  
n<sub>max</sub> = 4000 min<sup>-1</sup>

8 037 44 022	ø 16	2:1
8 037 44 023	ø 5/8"	2:1

▶ Weitere Ausführungen auf Anfrage  
further versions on request

▶ Zubehör ZB...\*  
accessories ZB...\*

▶ easy-quick

▶ u-tec



**Mehrspindelbohrkopf**  
**multi spindle drilling head**

$n_{max} = 6000 \text{ min}^{-1}$

8 050 44 031	ER 16 AX u-tec	EK	1:1
8 050 44 032	ER 16 AX u-tec	IK 140 bar	1:1



**Mehrspindel-Winkelbohrkopf**  
**multi spindle radial head**

$n_{max} = 6000 \text{ min}^{-1}$

Mittenmaß / center distance  $H=85$

8 053 44 027	ER 16 AX u-tec	EK	1:1
8 053 44 028	ER 16 AX u-tec	IK 140 bar	1:1

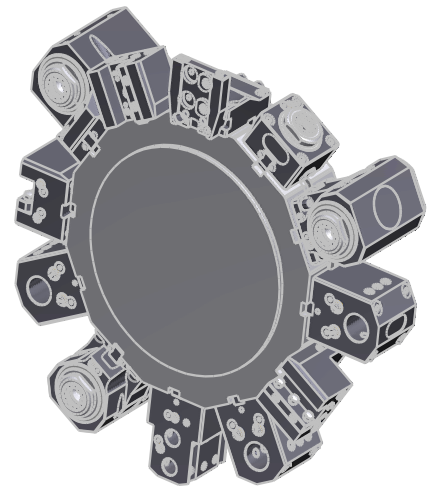

**feste Werkzeuge**  
**static tool holders**

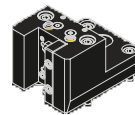

**Kombi-Drehstahlhalter**  
**universal turning holder**

8 224 04 022	Vierkant/square 20	EK
8 224 04 023	Vierkant/square 3/ 4"	EK

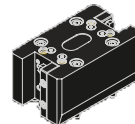

**Kombi-Doppel-Drehstahlhalter**  
**combi double turning holder**

8 251 04 016	Vierkant/square 20	EK
8 251 04 017	Vierkant/square 3/ 4"	EK

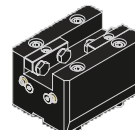

**Kombi-Plandrehhalter**  
**combi facing holder**

8 244 04 000	Vierkant/square 20	EK
8 244 04 007	Vierkant/square 3/ 4"	EK



**Bohrstangenhalter**  
**boring bar holder**

Mittenmaß / center distance  $H=85$

8 240 07 018	ø25	IK/EK
8 240 08 021	ø32	IK/EK
8 240 09 017	ø40	IK/EK
8 240 07 019	ø1"	IK/EK
8 240 07 015	ø1 1/4"	IK/EK
8 240 08 022	ø1 1/2"	IK/EK

► Weitere Ausführungen auf Anfrage  
further versions on request

► Zubehör ZB...\*  
accessories ZB...\*

► easy-quick

► u-tec





**Bohrstangenhalter**  
boring bar holder

Mittenmaß / center distance H=100

8 240 07 020	ø25	IK/EK
8 240 08 023	ø32	IK/EK
8 240 09 018	ø40	IK/EK
8 240 07 021	ø1"	IK/EK
8 240 07 016	ø1 1/4"	IK/EK
8 240 08 024	ø1 1/2"	IK/EK

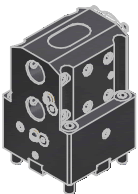
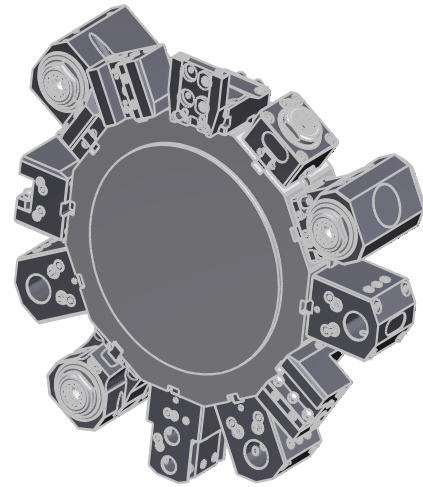

**Doppel-Bohrstangenhalter**  
double boring bar holder

Mittenmaß / center distance H=55/90

8 253 07 012	ø25	IK/EK
8 253 07 013	ø1"	IK/EK



**Doppel-Spannzangenhalter**  
double collet chuck holder

Mittenmaß / center distance H=85

8 249 05 000	ER 25	IK/EK
8 249 06 002	ER 32	IK/EK

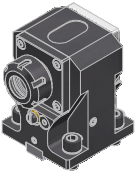

**Spannzangenhalter**  
collet chuck holder

Mittenmaß / center distance H=85

8 240 05 006	ER 25	IK/EK
8 240 06 013	ER 32	IK/EK

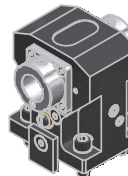

**Doppel-Spannzangenhalter**  
double collet chuck holder

Mittenmaß / center distance H=85

8 249 06 003	easy quick HT 4	IK/EK
--------------	-----------------	-------

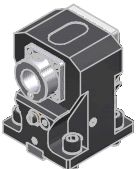

**Spannzangenhalter**  
collet chuck holder

Mittenmaß / center distance H=85

8 240 06 014	easy quick HT 4	IK/EK
--------------	-----------------	-------

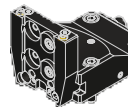

**Abstechhalter**  
cut-off holder

höhenverstellbar / height adjustable

8 320 02 010	SH 26	EK
--------------	-------	----

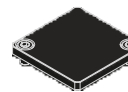

**Abdeckplatte**  
cover plate

8 200 99 000

▶ Weitere Ausführungen auf Anfrage  
further versions on request

▶ Zubehör ZB...\*  
accessories ZB...\*



▶ easy-quick



▶ u-tec



► **easy-quick HT Schnellwechselsystem**  
*easy-quick HT fast change system*

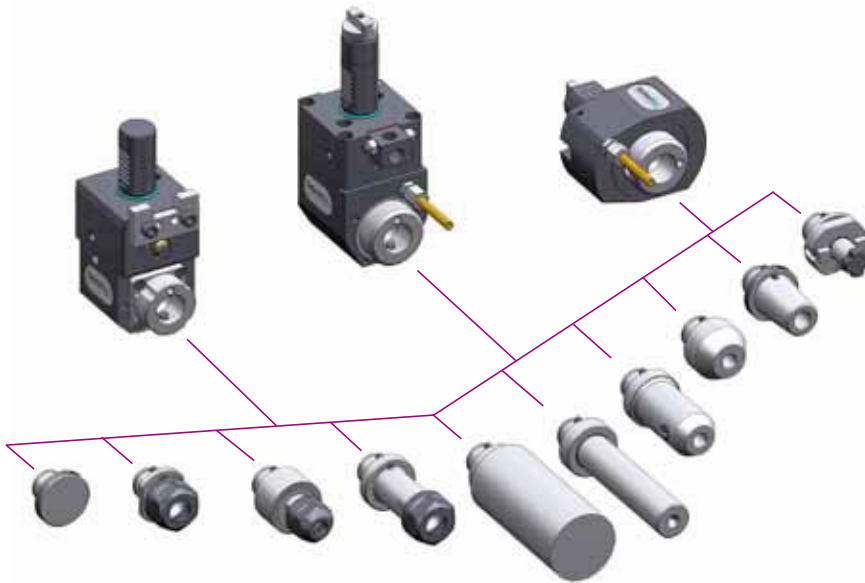

DAS Schnellwechselsystem von heimatec  
für angetriebene und feste Werkzeuge

*THE fast change system of heimatec  
for driven and static tools*

[www.heimatec.de](http://www.heimatec.de)  
Produkte / easy-quick

[www.heimatec.com](http://www.heimatec.com)  
products / easy-quick

► Ausführungen siehe Katalog  
versions see catalogue



► **u-tec<sup>®</sup> UT Wechselsystem**  
*u-tec<sup>®</sup> UT change system*

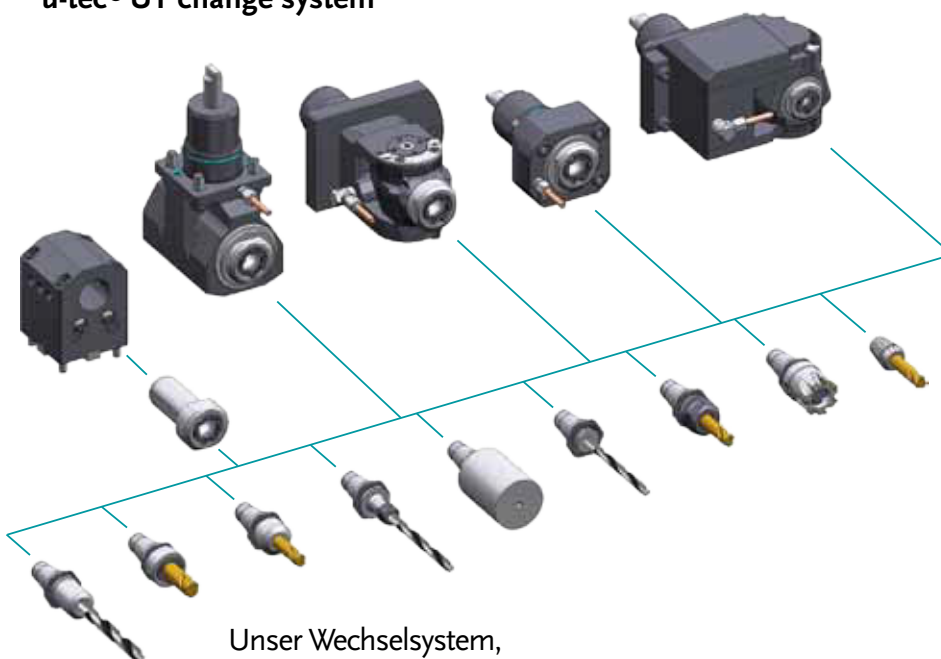

Unser Wechselsystem,  
das ALLES möglich macht

Our change system,  
that makes EVERYTHING possible

[www.heimatec.de](http://www.heimatec.de)  
Produkte / u-tec

[www.heimatec.com](http://www.heimatec.com)  
products / u-tec

► Ausführungen siehe Katalog  
versions see catalogue



# heimatec®

- heimatec®-Niederlassungen  
*heimatec® overseas branches*
- unsere weltweiten Vertretungen  
*global representations of heimatec®*



## Hauptsitz/headquarters

heimatec® GmbH  
Präzisionswerkzeuge  
Carl-Benz-Straße 4  
D- 77871 Renchen  
Postfach 11 36  
D- 77867 Renchen  
Tel.: +49 (78 43) 94 66 0  
Fax: +49 (78 43) 94 66 66  
heimatec.de  
info@heimatec.de

heimatec® Inc.  
USA  
usa.heimatec.com  
USA@heimatec.com

heimatec®-Ost, JSC  
Russia  
ru.heimatec.com  
Russia@heimatec.com

heimatec® Ltd.  
Taiwan  
tw.heimatec.com  
Taiwan@heimatec.com

heimatec®  
Singapore  
sg.heimatec.com  
Singapore@heimatec.com